



Pack 355 Pinewood Derby Rules



REVISED: 2018

CAR SPECIFICATIONS:

- Max Width: 2.75 (2 $\frac{3}{4}$) inches
- Max Length: 7" inches
- Max Weight: 5.00 Ounces
- Width between wheels: 1.75 (1 $\frac{3}{4}$) inches
- Min Bottom clearance: $\frac{3}{8}$ inch

RULES:

PARTICIPATION

Open to all Pack 355 Lions, Cub Scouts, Webelos, AOLers, siblings of the Scout, adult partners and leaders. **You must be present to race!**

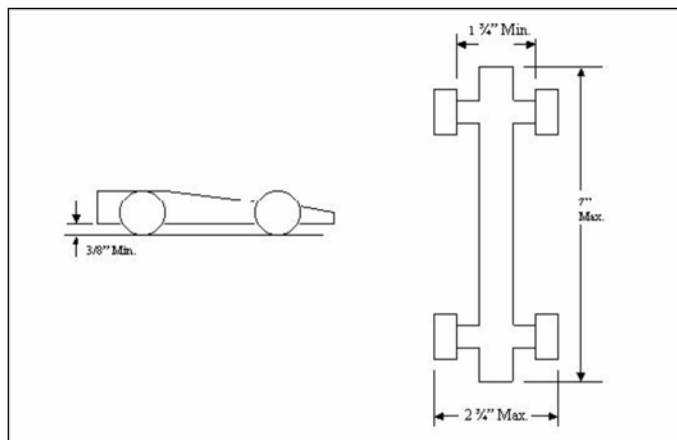

Figure 1 - Pinewood Derby Car Dimension Requirements

INSPECTION

Each car must pass inspection by the official inspection judges before it may compete. All cars will be inspected during registration for compliance to the specifications set forth in these rules. If, at registration, a car does not pass inspection, the owner will be informed of the reason for failure, and will be given time within the official registration time period to make adjustments. Cars built for previous race years will not be allowed to register. Nor can the wheels and/or axles from such a car be transferred to a new car. All cars will be assigned a number for identification. **NO LUBRICANTS MAY BE USED ONCE THE CARS ARE IMPOUNDED!**

CONSTRUCTION

All cars entered to race must be built by the Scout with an age appropriate level of assistance from an adult partner. One of the primary purposes of the Pinewood Derby is for the Scout to learn to work with tools and do their best to build something with an adult partner. Purchase of complete, pre-cut or pre-built Derby cars is strictly forbidden and goes completely against all of what the Pinewood Derby stands for.

IMPOUND

Cars will be impounded once registered. After being impounded, repairs will be limited to axles/wheels that are broken/lost or have fallen off the car during the race. Time for the repairs will be limited to a maximum of 5 minutes. Cars may not be modified after passing inspection. Only Track Officials may handle cars once they are impounded, except in the case of repairs, as specified above. Cars will be placed on the track and individually aligned and double-checked prior to the start of each heat.

BODY

The body in the Official BSA Pinewood Derby Kit must be used. Bodies made of other materials are grounds for disqualification. The body may be shaped, hollowed out, or built up from the original block, as long as it meets all other specifications. Details, such as steering wheel and driver, are permissible as long as these details do not exceed the maximum length, width and weight specifications. Any additions to the original body, i.e. steering wheels, drivers, decals, paint, weights, etc., must be firmly attached but need not be official BSA products. Any cosmetic additions/details that fall or break off during the racing event will not be reattached.

WHEELS AND AXLES

Wheels and axles must be the ones furnished in the official kits. Wheel bearings, washers, and bushings are prohibited. The car shall not ride on springs. Only official Cub Scout Grand Prix Pinewood Derby wheels and axles are permitted. BSA Grand Prix Pinewood Derby wheels and axles that have been altered (smoothed, machined, polished, etc.) and resold by third parties are not allowed. All work on wheels and axles must be performed by the scout and/or adult partner. Cars using illegal wheels or axles will be disqualified. Axles may not be coated to reduce friction or increase diameter. Dry lubricant is not considered a coating as specified in the "Lubricants" section. Wheels may be sanded to remove the flashing only. While the tread surface may be smoothed, any alteration to the tread width, thickness, or shape is not allowed. Partial reductions to the wheel diameter by shaving are allowed solely for the purpose of "truing" up the diameter of the wheel (making it more "round"). Lathes may not be used on a wheel. If the little bumps that are along the outer diameter of the wheel are gone, the tread thickness has been reduced too

WHEELS AND AXLES (cont.)

much and the wheel is illegal (see Figure 2). No coverings (e.g. hubcaps) are allowed on the external hub side of the wheels as this would prevent inspection of the axles and wheel hubs.



Figure 2 - Illegal and legal wheel modifications

WEIGHT

The weight of the race-ready car must not exceed five (5.00) ounces as measured on the official scale used during registration.

HEIGHT

The maximum car height will be 4 inches. This is to ensure that the cars are able to pass beneath the track finish line detector.

LUBRICANTS

Only dry graphite or dry graphite/moly lubricant may be used for lubrication. No liquid lubricants, waxes, polishes, soap or other lubricants are permitted.

OTHER

Cars must free-wheel with no stored energy, moving weights or starting devices. Sticky surfaces, magnets or any other devices or methods intended to gain an unfair advantage ("starting device" or "down-track booster") are illegal.

There is no designated front or back to the supplied body, either end may be the front. The original axle slots do NOT have to be used.

The bottom side of the car's front end where it rests against the starting peg can be no higher than 1 ½" from the track surface. This will ensure the car properly rests against the starting peg.

DETERMINING FINALISTS

Racers will be divided into LION, TIGER, WOLF, BEAR, WEBELOS, and AOLER participant divisions. Finalist determination will be on a time basis where average time is used with the slowest heat eliminated for each competitor to determine the three fastest finalists in each division (all computed by the race management software). Each car will race on every racing lane on the track. Individual heats may be rerun at the discretion of the race judges (in the event of a car hopping a lane which impacts another racer) – the decisions of the race judges are final (but made in the interest of fairness). In addition, there will be a racing division for siblings and adults where others can build their own cars. Once a car has been raced, if it is not the fastest in that division, it may be returned to the scout. The fastest car in each division will go on to race in the Grand Finals.

DETERMINING GRAND FINALIST

Finalists will be the individual fastest car in each division (excluding Sibling/Adult division). The Grand Finalist will be determined in successive heats whereby each Finalist races in each lane of the track where the average time is used to determine the Grand Finalist with the slowest heat eliminated.

SPORTSMANSHIP

Cars will be disqualified if the Scout, participant or adult partners display unsportsmanlike conduct at the race site.

****** Scouting encourages good sportsmanship ******